

INVESTIGATION OF INFLUENCE OF ION NITRIDING IN THE GLOW DISCHARGE WITH MAGNETIC FIELD ON MICROSTRUCTURE AND MICROHARDNESS OF STEEL HSS M2 WITH PRELIMINARY PLASTIC DEFORMATION

*Ivan Dmitrievich Sklizkov ^a, Ruslan Karimovich Vafin,
Alexandr Vladislavovich Asylbaev, Daniil Valerievich Mamontov*

Ufa University of Science and Technology, Zaki Validi str. 32, 450076, Ufa, Russia

^a sklizkovivan99@gmail.com

ABSTRACT

This work was devoted to the study of the influence of magnetic field on microhardness of HSS M2 steel during ion nitriding in the glow discharge. The samples were preliminarily subjected to intense plastic torsion deformation (IPTD). Standard methods of optical metallography and microhardness measurements were used in the experiments. It was found that IPTD allows creating ultrafine-grained (UFG) structure in the material, and magnetic field allows intensifying the process of ion nitriding by increasing the number of ionization acts, which leads to an increase in the thickness of the diffusion layer and microhardness compared to ion nitriding without preliminary IPTD and without magnetic field. The results obtained indicate the importance of using a magnetic field during ion nitriding in the glow discharge. The described effects are of potential interest for improving the mechanical properties of high-speed steels.

KEYWORDS

Magnetic field; ion nitriding; intense plastic torsion deformation (IPTD); ultrafine-grained (UFG); glow discharge.

ИССЛЕДОВАНИЕ ВЛИЯНИЯ ИОННОГО АЗОТИРОВАНИЯ В ТЛЕЮЩЕМ РАЗРЯДЕ С МАГНИТНЫМ ПОЛЕМ НА МИКРОСТРУКТУРУ И МИКРОТВЕРДОСТЬ СТАЛИ Р6М5 С ПРЕДВАРИТЕЛЬНОЙ ПЛАСТИЧЕСКОЙ ДЕФОРМАЦИЕЙ

*Иван Дмитриевич Склизков ^a, Руслан Каримович Вафин,
Александр Владиславович Асылбаев, Даниил Валерьевич Мамонтов*

Уфимский университет науки и технологий, Россия, 450076, Уфа, ул. Заки Валиди, 32

^a sklizkovivan99@gmail.com

АННОТАЦИЯ

Данная работа была посвящена исследованию влияния магнитного поля на микротвердость стали Р6М5 при ионном азотировании в тлеющем разряде. Предварительно образцы подверга-

лись интенсивной пластической деформации кручения (ИПДК). В экспериментах использовались стандартные методы металлографии, растровой электронной микроскопии и измерения микротвердости. Кроме того, определялась зависимость микротвердости от глубины упрочнения. Установлено, что ИПДК позволяет создать в материале ультрамелкозернистую структуру, а магнитное поле – интенсифицировать процесс ионного азотирования за счет увеличения числа ионизации, что приводит к увеличению толщины диффузионного слоя и микротвердости по сравнению с ионным азотированием без предварительного ИПДК и без магнитного поля. Полученные результаты свидетельствуют о важности использования магнитного поля при ионном азотировании в тлеющем разряде. Описанные эффекты представляют потенциальный интерес для улучшения механических свойств быстрорежущих сталей [1–3].

КЛЮЧЕВЫЕ СЛОВА

Магнитное поле; ионное азотирование; интенсивная пластическая деформация кручения (ИПДК); ультрамелкозернистая (УМЗ); тлеющий разряд.

Introduction

One of the key factors determining the strength and durability of materials is their surface hardness. To achieve increased hardness and wear resistance, surface modification methods, such as ion nitriding, are widely used. Ion nitriding having high efficiency allows creating on the surface of the material a hardened layer with high hardness and wear resistance [1–3].

However, in recent years, it has been found that the efficiency of ion nitriding can be significantly increased by combining this process with a preliminary intense plastic torsion deformation (IPTD). IPTD promotes the formation of a fine-grained structure on the surface of the material, which leads to an increase in the surface free energy and, as a result, enhanced nitrogen adsorption and nitride formation in the near-surface layer. In addition, IPTD leads to the formation of additional dislocations and microdefects, which promotes the activation of diffusion processes and, as a result, increases the thickness of the hardened layer [4–8].

However, the question of the influence of a magnetic field on the process of ion nitriding in combination with IPTD remains open. The magnetic field can have a significant effect on the processes of interaction of atoms and ions with the surface of the material, as well

as on the processes of diffusion and recrystallization. Thus, the study of the influence of the magnetic field on the process of ion nitriding of M2 steel with preliminary IPTD is an actual and promising direction of research in the field of surface modification of materials. [9–12].

In this work, the effect of magnetic field on the process of ion nitriding of M2 steel with preliminary intensive plastic torsion deformation was investigated. Changes in the microstructure and hardness of near-surface layers of samples after these processes were studied. The results of the study will allow us to understand more deeply the mechanisms of interaction of atoms and ions with the surface of the material when using a magnetic field, as well as to optimize the process of ion nitriding in combination with preliminary IPTD to obtain materials with increased surface hardness and wear resistance [13, 14].

1. Research Methodology

In the context of material selection for the study of the ion nitriding process, M2 high-speed tool steel was chosen. In order to study the effect of intense plastic deformation of the steel on the characteristics of the hardened layer after ion nitriding, an ultrafine-grained structure (UFG) (Fig. 1) was created on the surface of half of the samples using intense plastic torsion

deformation. To realize the IPTD process, the specimens with a disk shape of 20 mm diameter and 3 mm thickness were subjected to 43%

cold precipitation and 1.5 turns rotation at a hydrostatic pressure of 4 GPa, according to the scheme in Fig. 2.

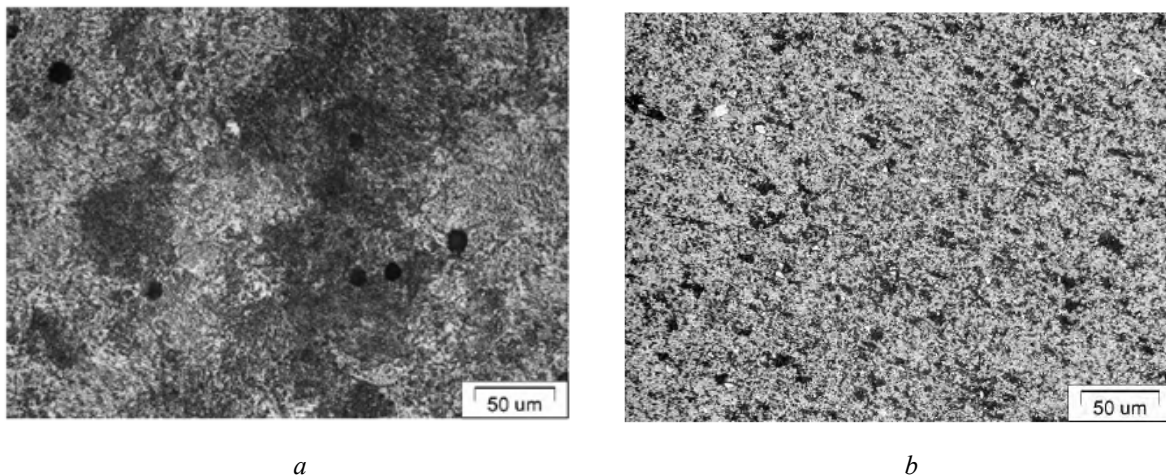

Fig. 1. Optical images of P6M5 microstructure:
a – Initial structure; *b* – UFG structure

Рис. 1. Оптические изображения микроструктуры P6M5:
a – исходная структура; *b* – структура УМЗ

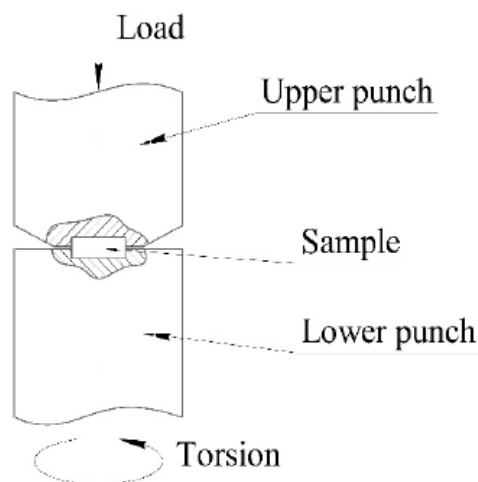

Fig. 2. Schematic diagram of the process of severe plastic deformation by torsion

Рис. 2. Схема процесса интенсивной пластической деформации кручением

Ion nitriding in the glow discharge plasma was carried out in the modernized vacuum unit ELU-5 (Fig. 3), designed for thermal and chemical-thermal treatments. Before the treatment in the vacuum chamber, ion cleaning of the specimen surface was carried out

for 15 min in argon atmosphere at pressure $P = 5$ Pa. Ion nitriding was carried out in the gas mixture of argon, nitrogen and hydrogen (50% Ar + 35% N₂ + 15% H₂) at gas pressure $P = 200$ Pa.

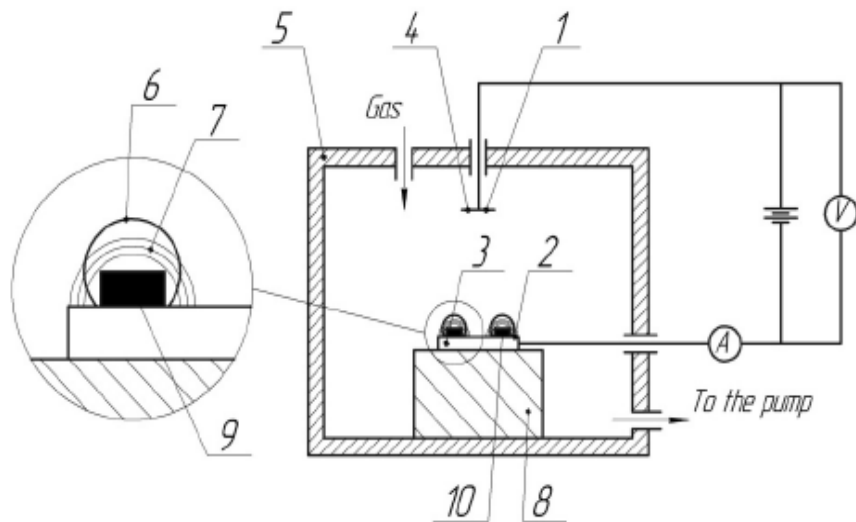

Fig. 3. Scheme of the experiment on the ELU-5M unit:
 1 – power source; 2 – cathode; 3 – magnetic system; 4 – anode; 5 – vacuum chamber;
 6 – toroidal field of bright glow; 7 – magnetic field lines; 8 – substrate;
 9 – Initial sample; 10 – IPTD sample

Рис. 3. Схема эксперимента на установке ЭЛУ-5М:
 1 – источник питания; 2 – катод; 3 – магнитная система; 4 – анод; 5 – вакуумная камера;
 6 – тороидальное поле яркого свечения; 7 – линии магнитного поля; 8 – подложка;
 9 – исходный образец; 10 – образец ИПДК

In this study we measured the microhardness and determined the depth of the hardened layer on specimens after ion nitriding in the glow discharge. For this purpose, an automatic microhardness tester with EMCO-Test DuraScan 50 image analysis system was used. This device provides the ability to accurately measure the microhardness of the material.

To reveal the microstructure, the investigated samples were chemically etched with a solution of 4% nitric acid diluted in ethanol.

To evaluate the thickness of the hardened layer, microstructures were imaged using an Olympus GX51 optical microscope. This microscope allows obtaining high-quality images and analyzing them to determine the thickness of the hardened layer.

2. Results and Discussion

In order to study the effect of ion nitriding with magnetic field of high-speed steel M2 with IPTD on surface microhardness and depth of hardened layer, two sets of samples were prepared. The first set of samples was not pre-treated (initial samples) and the second set was subjected to intense plastic torsion deformation (IPTD samples).

In the course of the study, the distribution of microhardness of the hardened layer by depth was obtained for samples with and without preliminary plastic deformation, after ion nitriding in the glow discharge plasma and after ion nitriding in the glow discharge plasma with a magnetic field. Duration of the nitriding process was $t = 2$ and 8 hours at temperature $T = 450$ °C. The obtained research results are presented in Fig. 4–9.

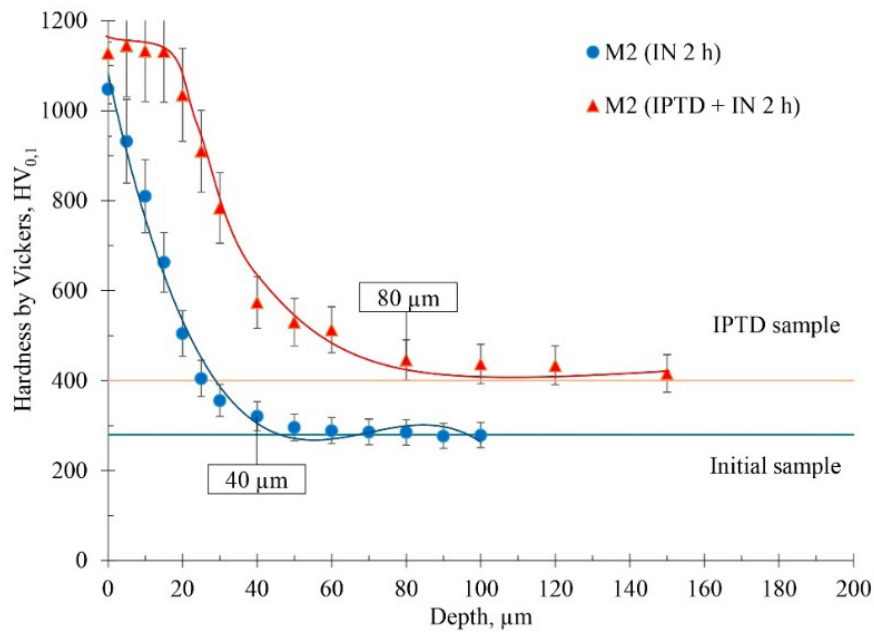

Fig. 4. Dependence of HV on the depth of the samples, treatment time 2 hours without magnetic field

Рис. 4. Зависимость микротвердости от глубины упрочненного слоя образцов, время обработки 2 часа без магнитного поля

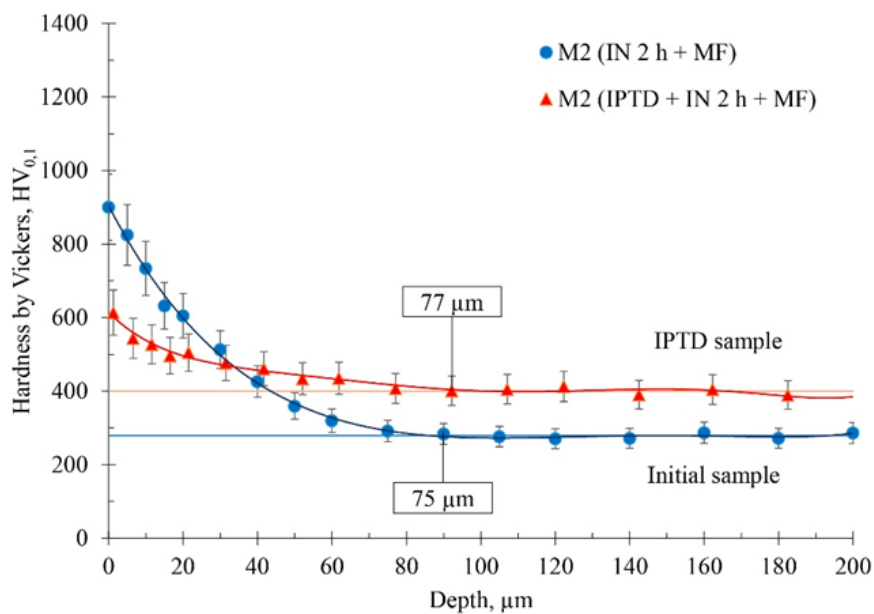

Fig. 5. Dependence of HV on the depth of the samples, treatment time 2 hours with magnetic field

Рис. 5. Зависимость микротвердости от глубины упрочненного слоя образцов, время обработки 2 часа с магнитным полем

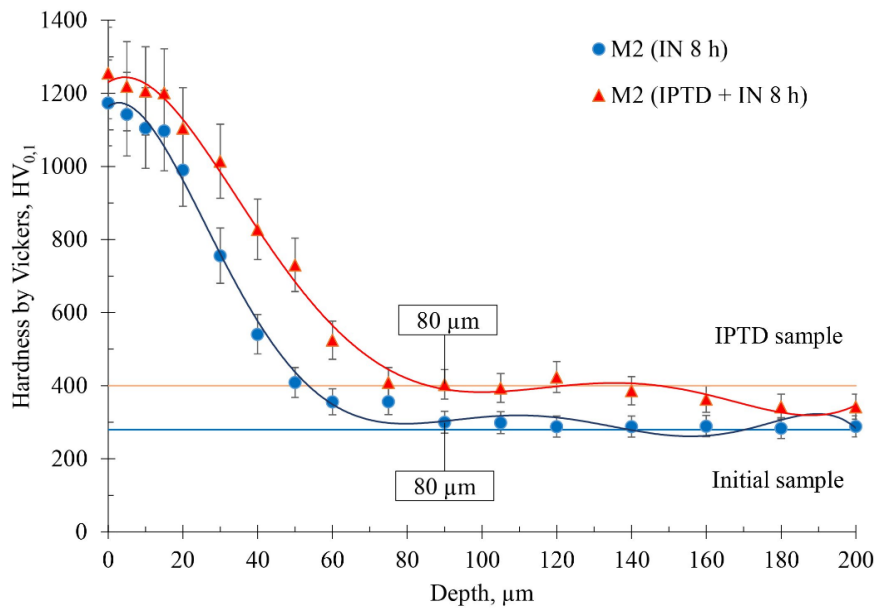

Fig. 6. Dependence of HV on the depth of the samples, processing time 8 hours without magnetic field

Рис. 6. Зависимость микротвердости от глубины упрочненного слоя образцов, время обработки 8 часов без магнитного поля

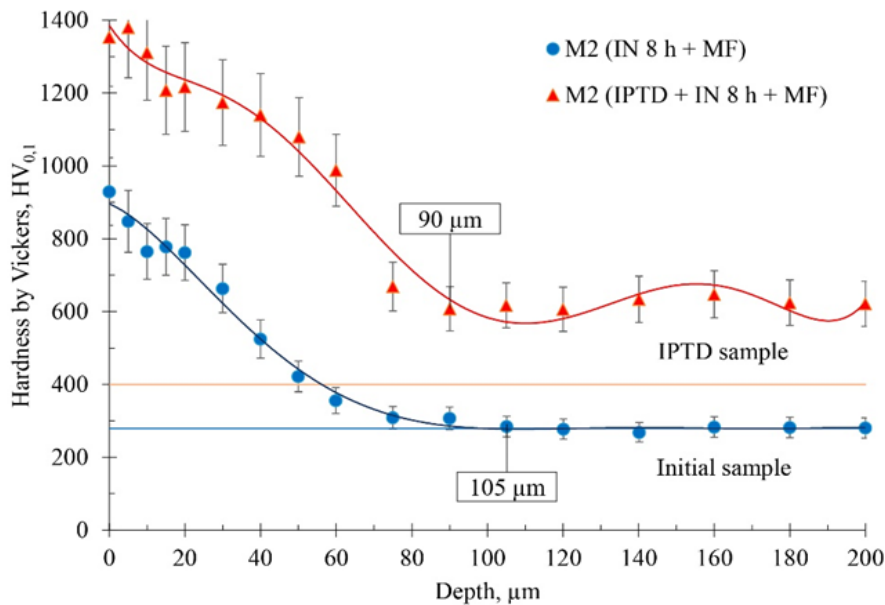

Fig. 7. Dependence of HV on the depth of the samples, treatment time 8 hours with magnetic field

Рис. 7. Зависимость микротвердости от глубины упрочненного слоя образцов, время обработки 8 часов с магнитным полем

Microhardness dependence graphs on the measurement depth under different nitriding conditions were analyzed. The samples were subjected to 2-hour and 8-hour nitriding without and in the magnetic field, and then their microhardness was measured and compared.

As a result of analysis of microhardness dependence on depth, it was found that the surface microhardness of samples at 2 hours nitriding was 1130 HV (IPTD sample) and 1050 HV (initial sample), while the hardened layer increased 2 times for IPTD sample and

was $\sim 80 \mu\text{m}$. At 2 x hour nitriding in a magnetic field, the surface microhardness of the IPTD sample was 615 HV, with a hardened layer thickness of $\sim 77 \mu\text{m}$. At the same time, the surface microhardness of the initial sample amounted to 900 HV, with the thickness of the hardened layer $\sim 75 \mu\text{m}$.

Similarly, at 8 h nitriding, the surface microhardness was 1260 HV (IPTD sample) and 1180 HV (initial sample), with a hardened layer thickness of $\sim 80 \mu\text{m}$ for both samples. At 8 h of nitriding in a magnetic field, the surface microhardness of the IPTD sample increased significantly to 1355 HV, and the thickness of the hardened layer also increased to $90 \mu\text{m}$. It was also found that the surface microhardness of the initial sample was 930 HV, while the thickness of the hardened layer increased to $105 \mu\text{m}$.

The increase in microhardness of samples with IPTD is due to the increase in the density of dislocations and the formation of microdefects, as well as grain refinement. As a result of these processes, the rate of diffusion of the saturating element into the material increases, which leads to an increase in microhardness of samples from high-speed steel M2. In addition, the increase in plasma concentration due to the magnetic field contributes to the increase in the rate of diffusion

of the saturating element deep into the material, which in turn also contributes to the increase in microhardness of the sample surface. [15–17].

In further study, the microstructure of M2 steel was analyzed before and after nitriding at 8 hours (Fig. 8, 9). The results obtained showed the presence of a hardened layer in the form of a dark etching zone. The formation of ultrafine-grained structure due to intense plastic torsion deformation contributes to the increase in the thickness of the nitride zone from $40 \mu\text{m}$ to $50 \mu\text{m}$ (1.25 times) after 8-hour nitriding. The visible increase in this zone is due to the formation of an ultrafine-grained structure, which has an increased dislocation density and forms microdefects and grain refinement. In addition, this structure contributes to an increase in the rate of diffusion of the saturating element deep into the material. As a result, there is a more intensive penetration of the saturating element, which in turn contributes to an increase in the thickness of the nitride zone [15–17]

The use of a magnetic field in the process of ion nitriding in the glow discharge leads to a significant improvement in the quality of the hardened layer. As shown in Fig. 9, at 8-hour nitriding the thickness of the nitride zone increases 1.5 times – from $61 \mu\text{m}$ (initial sample) to $95 \mu\text{m}$ (IPTD sample).

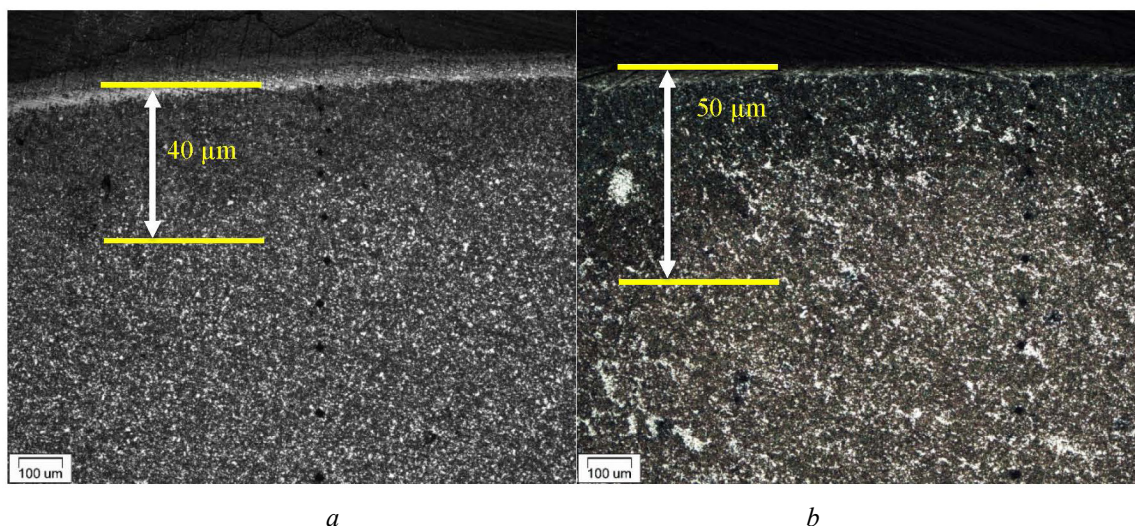

Fig. 8. Microstructure of M2 steel (a – Initial, b – IPDC) after ion nitriding in the glow discharge without magnetic field at $T = 450^\circ\text{C}$, $t = 8 \text{ h}$

Рис. 8. Микроструктура стали М2 (а – исходная, б – ИПДК) после ионного азотирования в тлеющем разряде без магнитного поля при $T = 450^\circ\text{C}$, $t = 8 \text{ ч}$

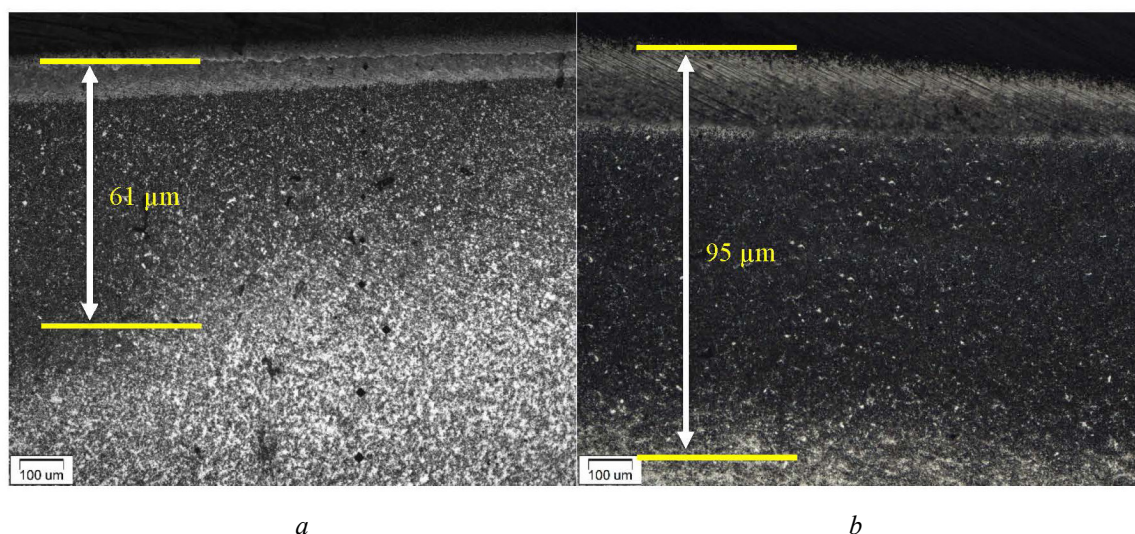

Fig. 9. Microstructure of M2 steel (a – Initial, b – IPDC) after ion nitriding in glow discharge with magnetic field at $T = 450^{\circ}\text{C}$, $t = 8\text{h}$

Рис. 9. Микроструктура стали М2 (а – исходная, б – ИПДК) после ионного азотирования в тлеющем разряде с магнитным полем при $T = 450^{\circ}\text{C}$, $t = 8\text{ ч}$

Application of magnetic field creates favorable conditions for sorption processes. This allows achieving high concentration of the diffusing element on the cathode surface, which leads to the formation of a high concentration gradient. Such concentration gradient provides more effective hardening of the material and increases its mechanical properties.

Conclusions

In the course of the study it was found that:

1. The use of magnetic field has a significant effect on the thickness of the hardened layer leading to its increase up to 2 times.
2. The use of magnetic field increases the surface microhardness up to 1.5 times at ion nitriding of M2 steel after severe plastic deformation.

REFERENCES

1. Arzamasov B. N., Bratukhin A. G., Eliseev Y. S., Panayoti T. A. Ionic chemical-thermal treatment of alloys. Moscow: Bauman Moscow State Technical University, 1999. P. 400.
2. Mamontov D. V., Sklizkov I. D., Asylbaev A. V., Vafin R. K. Influence of severe plastic deformation on the hardened layer characteristics of high-speed tool steel

HSS M2 // Materials. Technologies. Design. 2022. V. 4, Iss. 1(7). P. 30–38. DOI: 10.54708/26587572_2022_41730.

3. Franciskowska A., Pinkowski B. Iron nitrided with magnetic field influence // Journal of Achievements in Materials and Manufacturing Engineering. 2006. V. 18, Iss. 1. P. 17–24.

4. Kotov A. V. Improvement of Ion Nitriding Efficiency through Intense Plastic Torsion Deformation // Journal of Materials Science. 2020. V. 55, Iss. 15. P. 6712–6722.

5. Gupta T. P., Basak R. Surface modification of materials using ion nitriding and intense plastic torsion deformation: A review // Surface Engineering. 2021. V. 37, Iss. 2. P. 113–125.

6. Razumov N. G. Influence of Intense Plastic Torsion Deformation on the Properties of Ion-Nitrided Steels // Materials Science and Engineering: A. 2019. V. 743. P. 127–134.

7. Al-Mayouf A. M. Effect of Combination Process of Intense Plastic Torsion Deformation and Ion Nitriding on the Surface Properties of Materials // Materials and Manufacturing Processes. 2017. V. 32, Iss. 15. P. 1723–1733.

8. Janakiraman R. S. B. Intense Plastic Torsion Deformation Assisted Ion Nitriding of Ferrous and Nonferrous Materials // Journal of Heat Treatment and Materials. 2021. V. 76, Iss. 4. P. 251–258.

9. Ziegler G. G., Campetti E. G., Machado R. J. Influence of magnetic fields on ion nitriding process: An experimental study // Surface & Coatings Technology. 2009. V. 204, Iss. 6–7. P. 1100–1105.

10. Bamburov V. G., Khabibullin G. R., Tsivadze A. L. Effect of magnetic field on the process of ion nitriding of steel // *Russian Journal of Non-Ferrous Metals*. 2018. V. 59, Iss. 1. P. 5–8.
11. Dmitriev A. S. Effect of magnetic field and nitrogen ion energy on morphology and properties of ion implanted nitrided layers // *Surface & Coatings Technology*. 2016. V. 310. P. 21–29.
12. Delaunois F., Provitina O., Dubois J. M. Effect of a Magnetic Field on Surface Hardening // *Materials Science Forum*. 2015. V. 539–543. P. 4951–4956.
13. Saini N., Bala N. Influence of Magnetic Field on Surface Hardness and Wear Resistance of Materials: A Review // *Materials Today: Proceedings*. 2018. V. 5, Iss. 2. P. 4425–4432.
14. Pryanichnikov A. S., Maryaeva A. V. Investigation of the Effect of an External Magnetic Field on the Nitriding of Steel Cr12MoV // *IOP Conference Series: Materials Science and Engineering*, 2019. V. 542. Article number 012036.
15. Vasudevan S. Diffusion of Saturating Elements in Materials // *Journal of Materials Science*. 2010. V. 45, Iss. 10. P. 2547–2555.
16. Gupta R. Effect of Material Structure on Diffusion Rate of Saturating Elements // *Journal of Applied Physics*. 2010. V. 108, Iss. 5. Article number 053519.
17. Wu G., Peng B., Lin Y., Su Zh. Saturating Element Diffusion and Nitride Zone Growth in Materials // *Thin Solid Films*. 2011. V. 519, Iss. 22. P. 7958–7963. DOI: 10.1016/j.tsf.2011.05.047.